

Self-regulating heating cable

PRODUCT OVERVIEW

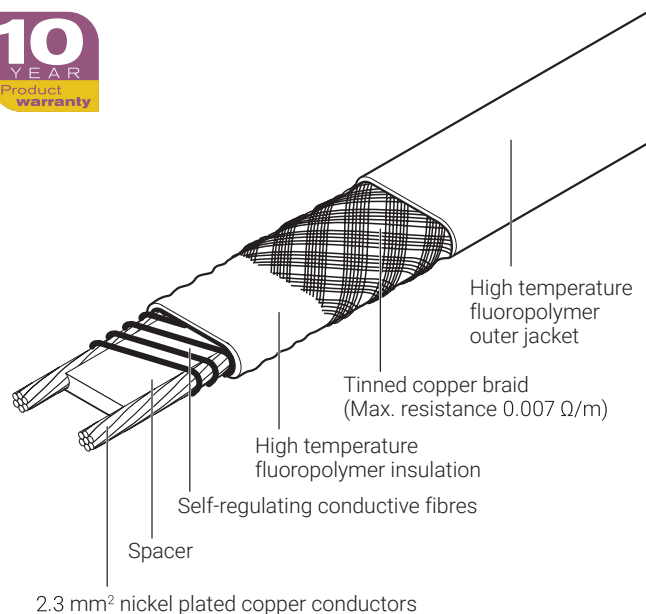

Electrical heat-tracing for process temperature maintenance applications up to 150°C which may be subject to steam cleaning.

The nVent RAYCHEM KTV family of self-regulating, parallel circuit heating cables is used for process temperature maintenance of pipes and vessels.

It can also be used for frost protection of large pipes and for applications requiring high temperature exposure capability.

Application

Traced surface type	Carbon steel Stainless steel Painted or unpainted metal
Chemical resistance	Organics and corrosives For aggressive organics and corrosives consult your local nVent representative

Supply voltage

230 Vac (Contact your local nVent representative for data on other voltages)

PRODUCT SPECIFICATIONS

Product dimensions and weight

Width x Thickness (nominal) mm	14.0 x 7.6
Weight (g/m)	250



Technical details

Maximum maintain or continuous exposure temperature (power on)	150°C
Maximum intermittent exposure temperature (power on/off)	250°C (*) Maximum cumulative exposure 1000 hours (*) The 250°C rating applies to all products printed "MAX INTERMITTENT EXPOSURE 250°C".
Minimum installation temperature	-60°C
Minimum bend radius	-60°C ≤ T < -20°C: 26 mm -20°C ≤ T < -10°C: 20 mm -10°C ≤ T < 0°C: 15 mm 0°C ≤ T < +10°C: 15 mm T ≥ +10°C: 12 mm

Thermal output rating

Nominal power output at 230 Vac on insulated steel pipes

- A 20KTV2-CT**
- B 15KTV2-CT**
- C 8KTV2-CT**
- D 5KTV2-CT**

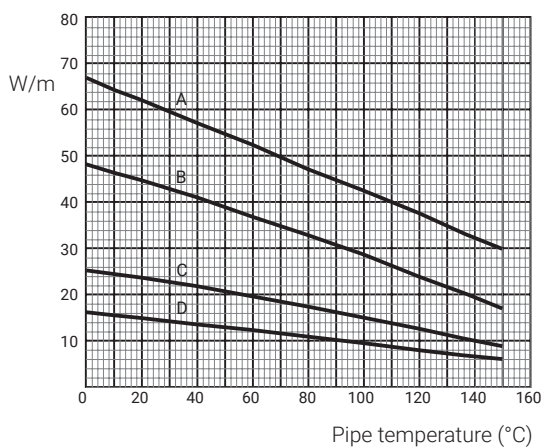

	5KTV2-CT	8KTV2-CT	15KTV2-CT	20KTV2-CT
Nominal power output (W/m at 10°C)	16	25	47	66

Maximum circuit length based on type 'C' circuit breakers according to EN 60898

Electrical Protection Sizing	Start-up Temperature	Maximum Heating Cable Length Per Circuit (m)			
16 A	-20°C	130	95	60	40
	+10°C	145	105	65	45
25 A	-20°C	205	150	90	65
	+10°C	230	165	100	75
32 A	-20°C	230	180	115	85
	+10°C	230	180	130	95
40 A	-20°C	230	180	130	105
	+10°C	230	180	130	110

The above numbers are for circuit length estimation only. For more detailed information please use the nVent RAYCHEM TraceCalc software or contact your local nVent representative. nVent requires the use of a 30 mA residual current device to provide maximum safety and protection from fire.

Where design results in higher leakage current, the preferred trip level for adjustable devices is 30 mA above any inherent capacitive leakage characteristic of the heater as specified by the trace heater supplier or alternatively, the next common available trip level for non adjustable devices, with a maximum of 300 mA. All safety aspects need to be proven.

APPROVALS

For use in ordinary and hazardous area Zone 1 and Zone 2 (Gas), Zone 21 and Zone 22 (Dust)

Temperature classification

T2: 5KTV2-CT , 8KTV2-CT , 15KTV2-CT , 20KTV2-CT (unconditional)

T6...T3: 5KTV2-CT , 8KTV2-CT , 15KTV2-CT , 20KTV2-CT (using stabilized design)

nVent RAYCHEM heat-tracing products are approved for the listed temperature classifications by using the principles of stabilized design (as per system classification approach). Use TraceCalc design software or contact nVent.

Product certification



More details about product certification, approvals and conditions of safe use are available in the installation manual for Self-regulating and Power limiting heating cable systems at www.nVent.com/RAYCHEM.

ORDERING INFORMATION

Part description	5KTV2-CT	8KTV2-CT	15KTV2-CT	20KTV2-CT
Part No.	P000001679	P000001681	P000001683	P000001685

Components

nVent RAYCHEM offers a full range of components for power connections, splices and end seals.

These components must be used to ensure proper functioning of the product and compliance with electrical requirements.

